



2024 Academic Challenge

ENGINEERING GRAPHICS TEST – SECTIONAL

Engineering Graphics Test Production Team

Ryan K. Brown, Illinois State University – Author/Team Leader
Ted Branoff, Illinois State University – Reviewer
Aaron M. White, Eastern Illinois University – Coordinator of Test Production

GENERAL DIRECTIONS

Please read the following instructions carefully. This is a timed test; any instructions from the test supervisor should be followed promptly.

The test supervisor will give instructions for filling in any necessary information on the answer sheet. Most Academic Challenge sites will ask you to indicate your answer to each question by marking an oval that corresponds to the correct answer for that question. One oval should be marked to answer each question. Multiple ovals will automatically be graded as an incorrect answer.

Be sure ovals are marked as  , not  ,  ,  , etc.

If you wish to change an answer, erase your first mark completely before marking your new choice.

You are advised to use your time effectively and to work as rapidly as you can without losing accuracy. Do not waste your time on questions that seem too difficult for you. Go on to the other questions, and then come back to the difficult ones later if time remains.

Time: 40 Minutes Number of Questions: 40

DO NOT OPEN TEST BOOKLET UNTIL YOU ARE TOLD TO DO SO!

© 2024 Eastern Illinois University
All Rights Reserved

Academic Challenge
Engineering Graphics Test (Sectional) – 2024

1. ASME standards for line conventions designate the _____ line for showing the shape of a part in an “alternate position.”

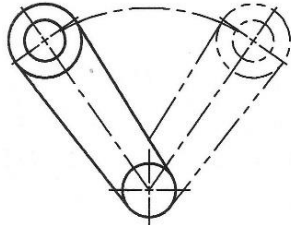

- A. chain
- B. phantom
- C. break
- D. hidden
- E. center

2. Which of the following distances below is incorrectly stated on the metric edge of this 6” steel rule?

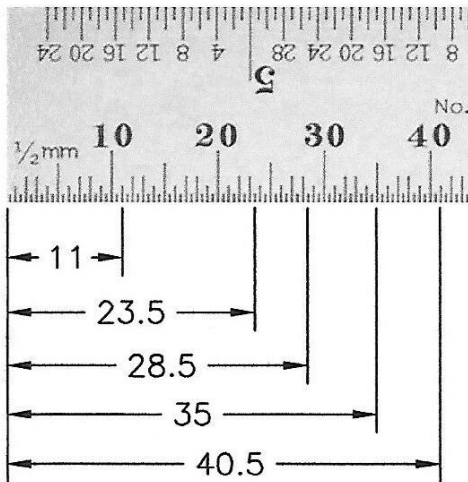

- A. 11
- B. 23.5
- C. 28.5
- D. 35
- E. 40.5

3. Which manufacturing term below can describe **pushing or forcing material through a shaped opening**, but also is used in 3D CAD systems as a term that describes a method of creating 3D model from a 2D shape?

- A. Fillet
- B. Inject
- C. Extrude
- D. Push
- E. Force

4. The 4' x 8' sheet of plywood was scaled to fit on a standard B-size sheet of paper. Which of the following scales matches the illustration?

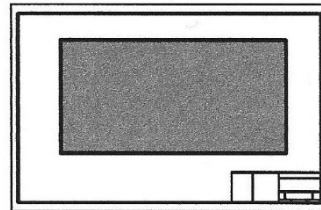

- A. 3" = 1'-0"
- B. 1-1/2" = 1'-0"
- C. 1" = 10'
- D. 3/16" = 1'-0"
- E. 1/4" = 1'-0"

5. ASME Y14.8 is entitled **Castings and Forgings**, which focuses on an area of manufacturing wherein parts are produced in a _____.

- A. mold
- B. milling machine
- C. 3D printer
- D. three-jaw chuck
- E. lathe

6. The principles of orthographic projection are explained in standards and textbooks with three principal projection planes: **frontal**, **horizontal**, and **profile**. Which two dimensions are projected onto the **profile** plane?
- A. Height and Width
 - B. Width and Length
 - C. Depth and Height
 - D. Width and Depth
 - E. Height and Length

7. CAD files are often used by the manufacturing team and the CAD data is processed into CNC programs that drive the tools that make the parts. What does **CNC** stand for?
- A. Computer Nominal Cutting
 - B. Computer Non-manual Control
 - C. Computerized Nozzle Cutting
 - D. Computer Numerical Control
 - E. Controlled Nominal Cutting

8. Which of the four choices, A-D, if any, has different **limits** than the other three?

- A. $\begin{array}{c} \leftarrow 1.563 \\ \leftarrow 1.553 \end{array}$
- B. $\begin{array}{c} \rightarrow 1.558 \pm .005 \\ \leftarrow \end{array}$
- C. $\begin{array}{c} \rightarrow 1.553 + .010 \\ \leftarrow \end{array}$
- D. $\begin{array}{c} \rightarrow 1.563 \begin{array}{l} +.000 \\ -.010 \end{array} \\ \leftarrow \end{array}$
- E. ALL OF THE ABOVE HAVE THE SAME TOLERANCE AND LIMITS

9. If a center line coincides with a hidden line:
- A. Omit whichever line that is least important to the print reader
 - B. Move the center line over a little
 - C. Omit the center line
 - D. Place an asterisk near the hidden line
 - E. Omit the hidden line

10. _____ is a field of study very important to, and integrated throughout, the field of engineering graphics.
- A. Sheet vellum
 - B. Secondary velocity
 - C. Spatial visualization
 - D. Solid volumetrics
 - E. Symmetrical video

11. What type of section view is illustrated below? (Cutting-plane line not shown)

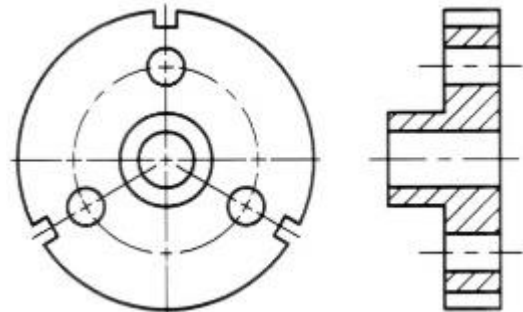

- A. Aligned
- B. Rotated
- C. Half
- D. Full
- E. Offset

12. Of the dimensions shown in the illustration below, which one does not follow standard practice?

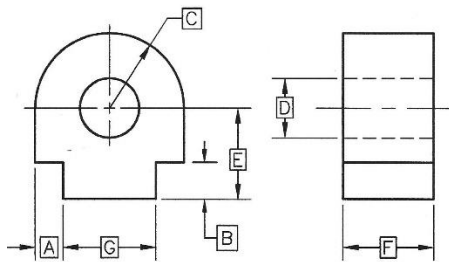

- A. A
- B. B
- C. C
- D. D
- E. E

13. The chart below shows recommended standard sizes and pitches for metric threads in design projects. Of the choices below, which metric thread would be the “closest” metric size, as compared to an inch-based thread with a specification of 3/4-10 UNC?

NOMINAL DIAMETER (mm)	THREAD PITCH (mm)		
	COARSE	FINE	EXTRA FINE
6	1		
8	1.25	1	1
10	1.5	1.25	1.25
12	1.75	1.5	
14	2	1.5	
16	2	1.5	
18	2.5	1.5	
20	2.5	1.5	
22	2.5	1.5	
24	3	2	
27	3	2	
30	3.5	2	

- A. M20 X 2.5
- B. M22 X 1.5
- C. M16 X 2
- D. M24 X 3
- E. M 20 X 1.5

14. Which one of the following symbols would NOT be found in a local note or callout, although it might be found in a feature control frame?

- A.
- B.
- C.
- D.
- E.

15. Which of the following will most likely require a **dimension line** that is in the form of an arc?

- A. Diameter of a bolt circle
- B. The radius size of a larger fillet
- C. Counter-bore depth dimension
- D. Angular dimension for an inclined wedge surface
- E. Location dimension for a threaded hole

16. In a typical high school drafting textbook, what would be a likely **chapter title** that explains how to design and draw detail drawings for the objects illustrated below?

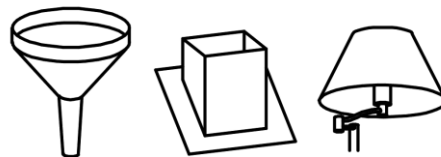

- A. Descriptive Geometry
- B. Section Views
- C. Auxiliary Views
- D. Developments and Intersections
- E. Structural Drafting

17. Convert the “F” shape below into a 3D “block letter”. How many line segments are required? (Note: Use a depth of one grid, corner-to-corner, at 45° slope up to the right.)

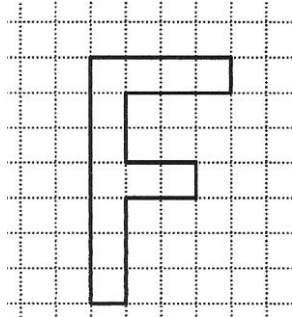

- A. 9
- B. 10
- C. 11
- D. 12
- E. 13

18. What is one error that needs fixed on the drawing below.

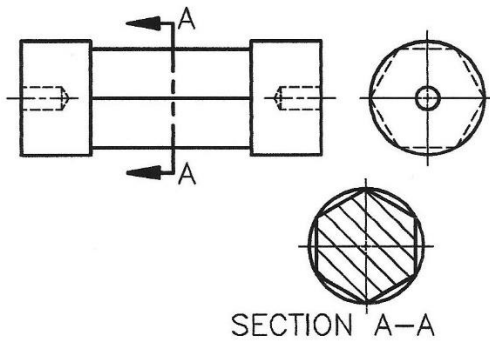

- A. The removed section is turned wrong
- B. The cutting plane arrows are pointing in the wrong direction
- C. The round view should be on the other side of the long view
- D. The section lines should be closer together
- E. The hidden lines for the holes should not be shown

19. Identify the tools pictured below.



- A. Reamers
- B. Broaching bits
- C. Counterdrills
- D. Taps
- E. Screw thread dies

20. Which of the choices below is a dimension that will create a clearance fit where the shaft has a tolerance of .004”, and the allowance is .004”?

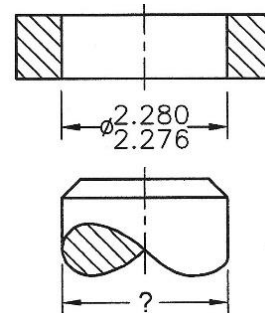

- A. $\left| \begin{array}{c} \phi 2.276 \\ \phi 2.272 \end{array} \right|$
- B. $\left| \begin{array}{c} \phi 2.272 \\ \phi 2.268 \end{array} \right|$
- C. $\left| \begin{array}{c} \phi 2.274 \\ \phi 2.270 \end{array} \right|$
- D. $\left| \begin{array}{c} \phi 2.270 \\ \phi 2.278 \end{array} \right|$
- E. $\left| \begin{array}{c} \phi 2.284 \\ \phi 2.278 \end{array} \right|$

21. The canvas tent shown below has no floor. The canopy is represented in the front view as an arc. Identify the **TRUE** statement below.

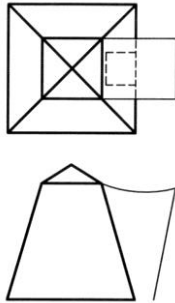

- A. The four triangles in the top view are shown true size and shape
 - B. The door opening would show true size and shape in the right side view if there was one
 - C. The canopy is shown true size and shape in the top view
 - D. The trapezoid in the front view is shown true size and shape
 - E. None of the canvas shapes showing in either front view or top view are shown true size and shape
22. The diagonal dashes lines in the figure below illustrate a principle that can be used to help maintain _____ while changing the scale of a shape.

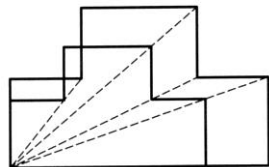

- A. symmetry
- B. proportion
- C. perspective
- D. stability
- E. construction

23. The illustration below features a front view, right side view, and an auxiliary view. Which of the statements below is a **FALSE** statement?

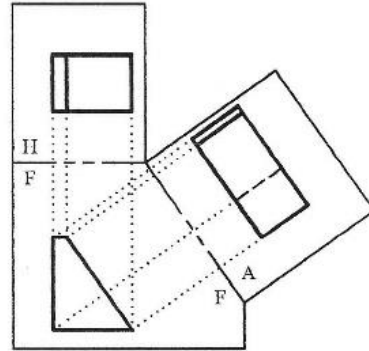

- A. An *auxiliary* projection plane is shown and the *profile* projection plane is omitted
 - B. The lines marked H-F and F-A are shown as folding “hinge” lines, but they can also be used as reference lines for transferring distances
 - C. On the horizontal and auxiliary planes, the distance from the folding line to the front surface is equal
 - D. The auxiliary view features the true depth of the object
 - E. The A-F folding line is at a 45° angle to solve for the true size and shape of the inclined surface
24. Two circles of different radii, one inside the other, without a common center point, are said to be _____.
- A. concentric
 - B. eccentric
 - C. circumscribed
 - D. radial
 - E. inscribed

PROBLEMS 25 & 26: CREATE ISOMETRIC SKETCHES
 SELECT AN ANSWER THAT REPRESENTS THE NUMBER OF SEGMENTS REQUIRED

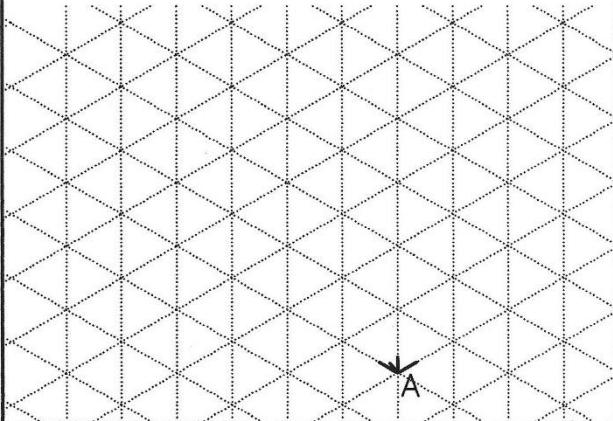
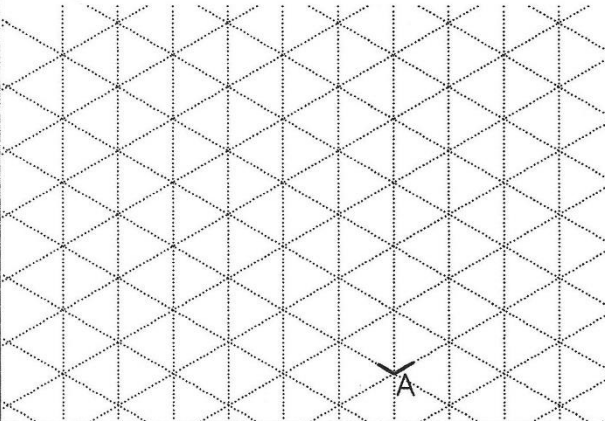
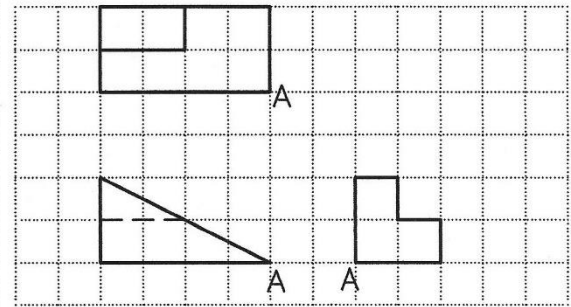
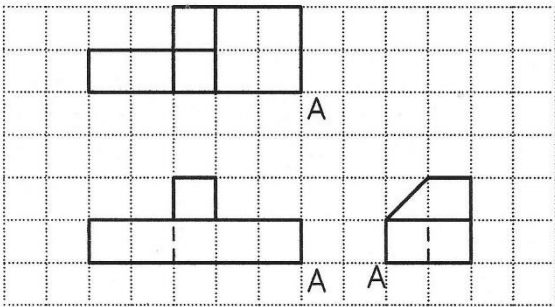

25. NUMBER OF LINE SEGMENTS:
 A. 15 B. 16 C. 17 D. 18 E. 19

26. NUMBER OF LINE SEGMENTS:
 A. 9 B. 10 C. 11 D. 12 E. 13

PROBLEMS 27 & 28: MISSING LINE PROBLEMS: SELECT AN ANSWER THAT
 CORRESPONDS WITH THE LEAST NUMBER OF LINE SEGMENTS (VISIBLE AND/OR
 HIDDEN) STILL NEEDED TO CREATE A CORRECT AND VALID MULTIVIEW DRAWING

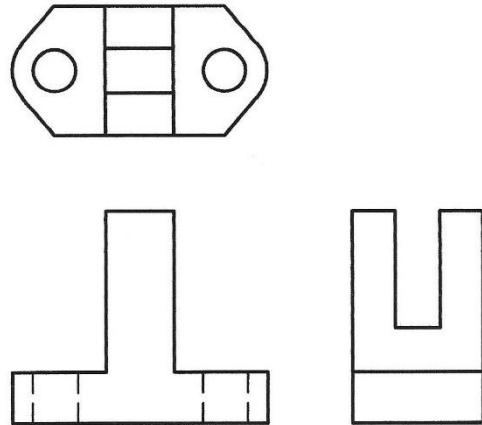
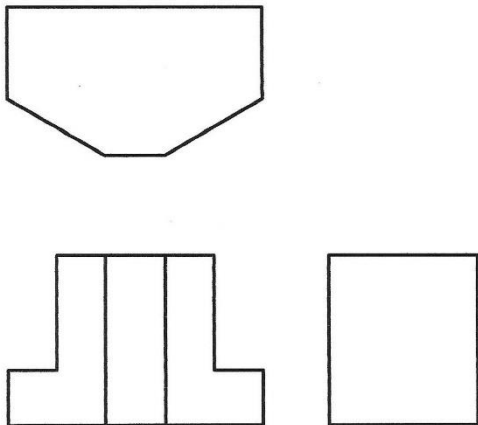

27. MINIMUM NUMBER OF LINES:
 A. 2 B. 3 C. 4 D. 5 E. 6

28. MINIMUM NUMBER OF LINES:
 A. 5 B. 6 C. 7 D. 8 E. 9

FOR EACH PROBLEM, SELECT THE CORRECT FRONT VIEW
 NOTE: CENTER LINES OMITTED ON THIS TEST PAGE

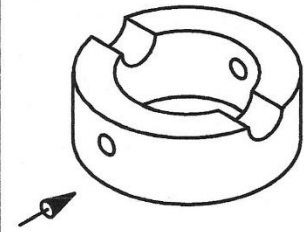

29.

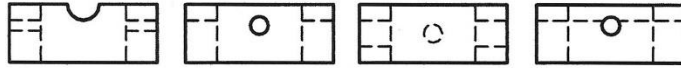

A.

B.

C.

D.

NONE
OF
THESE
E.

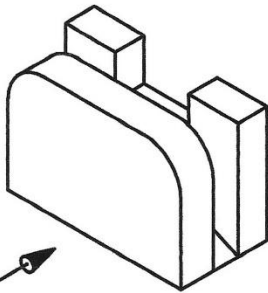

30.

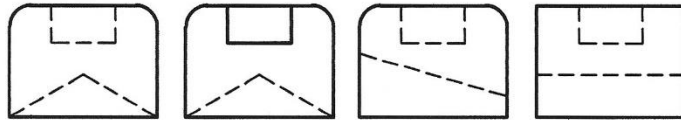

A.

B.

C.

D.

NONE
OF
THESE
E.

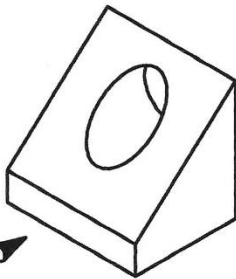

31.

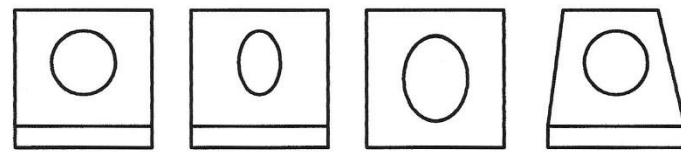

A.

B.

C.

D.

NONE
OF
THESE
E.

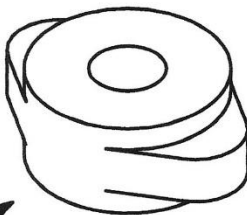

32.

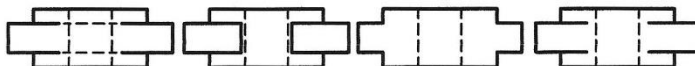

A.

B.

C.

D.

NONE
OF
THESE
E.

FOR EACH PROBLEM, SELECT THE CORRECT SIDE VIEW
 NOTE: CENTER LINES OMITTED ON THIS TEST PAGE

<p>33.</p> <p>?</p>	<p>A. B. C. D.</p> <p>NONE OF THESE E.</p>
<p>34.</p> <p>?</p>	<p>A. B. C. D.</p> <p>NONE OF THESE E.</p>
<p>35.</p> <p>?</p>	<p>A. B. C. D.</p> <p>NONE OF THESE E.</p>
<p>36.</p> <p>?</p>	<p>A. B. C. D.</p> <p>NONE OF THESE E.</p>

FOR EACH PROBLEM, SELECT THE CORRECT FRONT SECTIONAL VIEW
 NOTE: CENTER LINES OMITTED ON THIS TEST PAGE

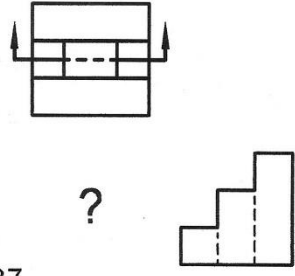
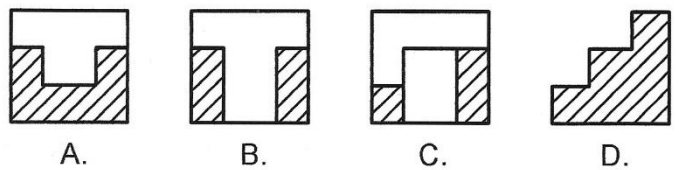
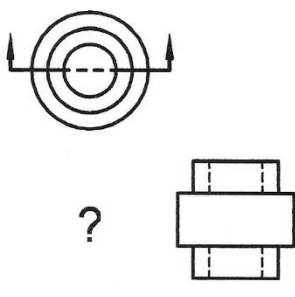
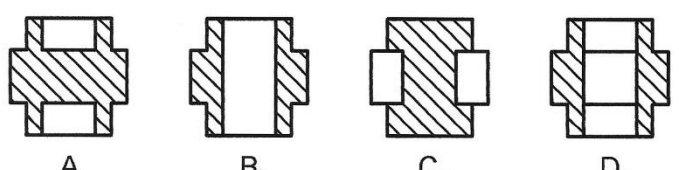
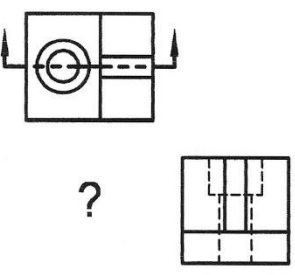
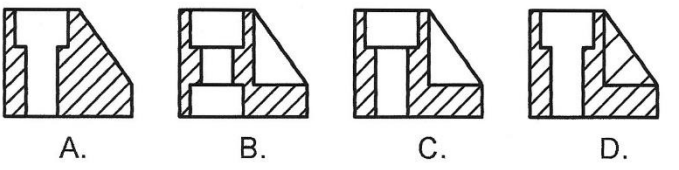
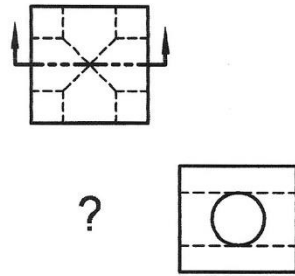
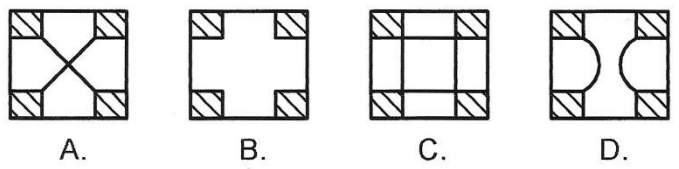
<p>37.</p> 	 <p>A. B. C. D. E. NONE OF THESE</p>
<p>38.</p> 	 <p>A. B. C. D. E. NONE OF THESE</p>
<p>39.</p> 	 <p>A. B. C. D. E. NONE OF THESE</p>
<p>40.</p> 	 <p>A. B. C. D. E. NONE OF THESE</p>

SCRATCH PAPER

